

P/N: FACM31H2-182Y10R0

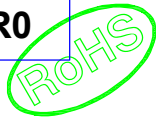

Outline Dimensions:(Unit:mm)

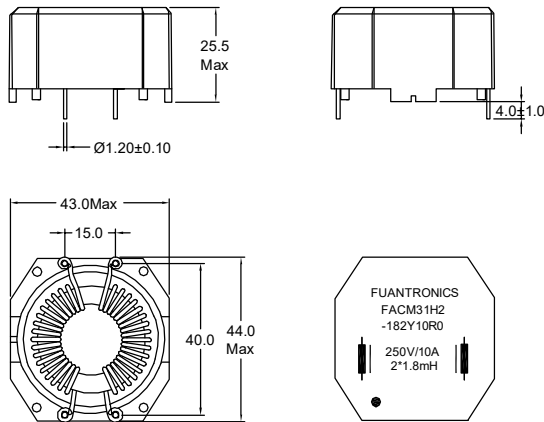

Electrical Schematic:

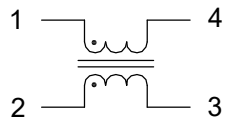

"•" Polarity point

Winding Construction:

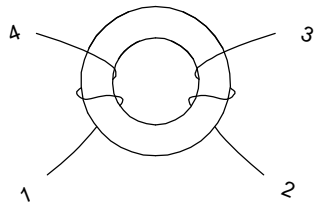

Electrical Characteristics:

Inductance: L1=L2=1.8mH ±30% at 10KHz 0.1V.  
 Rated current: 10.0Amps .  
 Hipot: coil-coil: 1500V/3mA/2S.  
 D.C.Resistance: R1=R2= 14.0 m Ω typ.  
 Turns ratio: 1:1±0Ts.

General Properties:

Operating Temperature:-40°C to +105°C.  
 Storage Temperature:-25°C to +60°C.  
 Insulation Class: B.  
 Weight: ≈ 70.0g。

Wave Soldering:

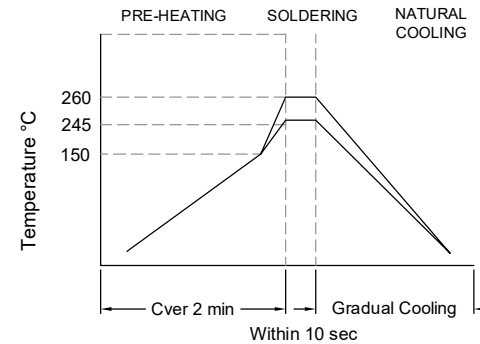

Note:  
 1.Never Contact the ceramic with the iron tip :  
 2.1.0mm tip diameter(max).

Current VS temperature rise:  
 (Simulation test curve)

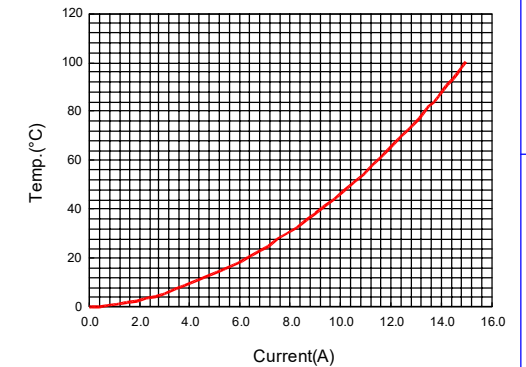

List of UL Certificate:

| No. | Part Name | Mat'l Description | Supplier                                 | UL Number |
|-----|-----------|-------------------|--|-----------|
| 1   | Core      | Toroid Core       | SuZhou GuanDa Magnet Co.,Ltd             | N/A       |
| 2   | Case      | CASE-31/PBT       | Chang Chun Plastics Co.,Ltd              | E59481    |
| 3   | Wire      | 2UEW-F/155°C      | Jiangsu Dartong M & E Co.,Ltd            | E237377   |
| 4   | Epoxy     | 808A/B-R(点胶线圈和底部) | Dong Guan Shi Pai Hua Chang Material Fty | E304477   |
| 5   |           |                   |  |           |

Tianchang Fuan Electronic Co., Ltd  
 www.fuantronics.net  
 TEL: +86-550-7814888  
 FAX:+86-550-7831133



Tolerances unless otherwise specified:  
 (X)±0.50 (XX)±0.25  
 Unit of measurement: mm

Drawn: *Jun*  
 Checked: *Benson*  
 Approved: *Amson*

**DRAWING TITLE**  
 Common Mode Choke

Material Number:

Customer P/N:  
 Document/Rev: FARD2302116/00  
 Specification Sheet: 1 of 1  
 Date of Recognition: Feb./16/2023

| REV | DESCRIPTION | APPD | DATE |
|-----|-------------|------|------|
|     |             |      |      |