

COIL FORMER

General data 10-pins EFD25/13/9 coil former

| PARAMETER                     | SPECIFICATION   |
|-------------------------------|---|
| Coil former material          | phenolformaldehyde (PF), glass-reinforced, flame retardant in accordance with "UL 94V-0"; UL file number E41429 |
| Pin material                  | copper-tin alloy (CuSn), tin (Sn) plated  |
| Maximum operating temperature | 180°C, "IEC 60085", class H   |
| Resistance to soldering heat  | "IEC 60068-2-20", Part 2, Test Tb, method 1B, 350 °C, 3.5 s   |
| Soldeerability                | "IEC 60068-2-20", Part 2, Test Ta, method 1,235°C,2s  |

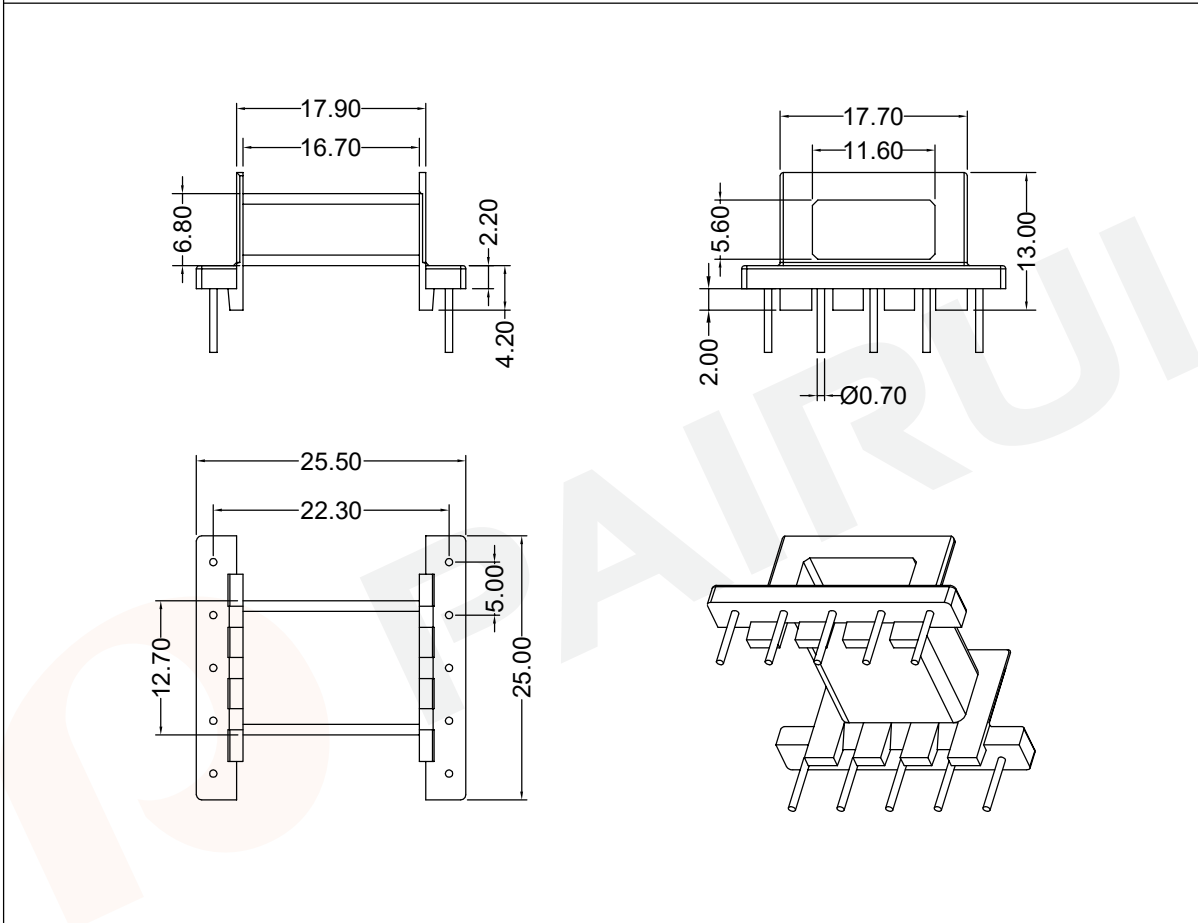

Winding data and area product for 10-pins EFD25/13/9 coil former

| NUMBER OF SECTIONS | WINDING AREA (mm <sup>2</sup> ) | MINIMUM WINDING WIDTH (mm) | AVERAGE LENGTH OF TURN (mm) | AREA PRODUCT Ae x Aw (mm <sup>4</sup> ) | TYPE NUMBER     |
|--------------------|---------------------------------|----------------------------|-----------------------------|---|-----------------|
| 1                  | 42                              | 16.70                      | 50                          | 2390                                    | EFD-2501-1S-10P |

Tolerances unless otherwise specified:  
 0<L≤4±0.10 4<L≤16±0.20  
 16<L≤45±0.30 45≤L±0.40  
 Pin Dim:±0.05 Thickness:±0.20 Pin Pitch:±0.20

Dimensions:  
(mm)



REMARK

Mould No.: EFD2501

Bobbin material: PM9820

Code No.: FAY01091

Available for Fuan core: EFD25/13/9



Fuan Electronics

TEL :0086-514-87693589  
 EML :sales@fuantronics.net  
 WEB:www.fuantronics.net

Make: P.Xiao

Material Number: A4H250100100

Checked: Beson. zhan

Document/Rev: 00

Approved: Anson. zhan

Date of Recognition: Oct./17/2019